

Shelby Williams®

TIPS FOR SPECIFYING BOOTHS & BANQUETTES

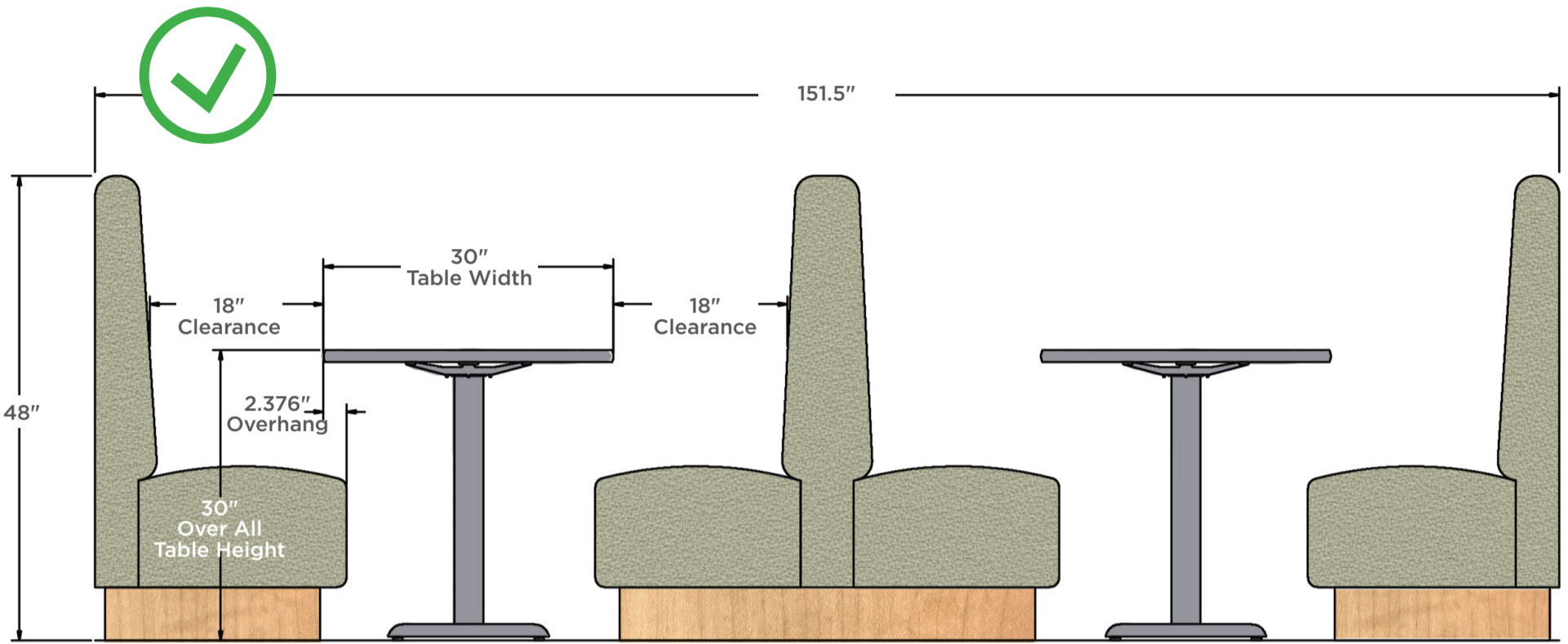

THE CRUNCHER

DESIGNER TIP

Avoid bases that have high arching legs that impune the users' comfort.

THE KNEE KNOCKER

DESIGNER TIP

Use table bases that have a center column or cantilever off the wall. (Remember that cantilevers require blocking in the wall.)

THE CHIN UP

DESIGNER TIP

When using Lounge Seating, 10" of space between the seat and table top is best. For dining, 12" is most comfortable. Exceeding 12" will make your chin feel like it is resting on the table.

COMMON MISTAKES TO AVOID

NOFLO

DESIGNER TIP

Always share the floor plan allowing the engineer to help maximize the effectiveness of your project and avoid unnecessary errors.

THE HIP JAB

DESIGNER TIP

Radius corners on the outside table top edges make getting in and out of the booth more comfortable.

THE BIG SPILL

DESIGNER TIP

Leaving too much space seems more comfortable, but it leaves the user too far from their work or meal.

SHORT CUT

DESIGNER TIP

Never settle for close enough. We are a "real" banquette manufacturer that can build the product to match your exact space or shape. Banquettes should help maximize your seating capacity.

THE BIG SQUEEZE

DESIGNER TIP

Tables should not overlap the booth seats more than 3" and should provide 18" of "gut space."