

CUSTOM BOOTHS ONE STEP AT A TIME

CUSTOM BOOTHS AS EASY AS 1 - 2 - 3!



1 KNOW YOUR SPACE, KNOW YOUR APPLICATION

- ✓ Restaurants
- ✓ Lobbies
- ✓ Community Centers
- ✓ Libraries
- ✓ Student Lounges
- ✓ Waiting Rooms
- ✓ Hospitals
- ✓ Public Spaces

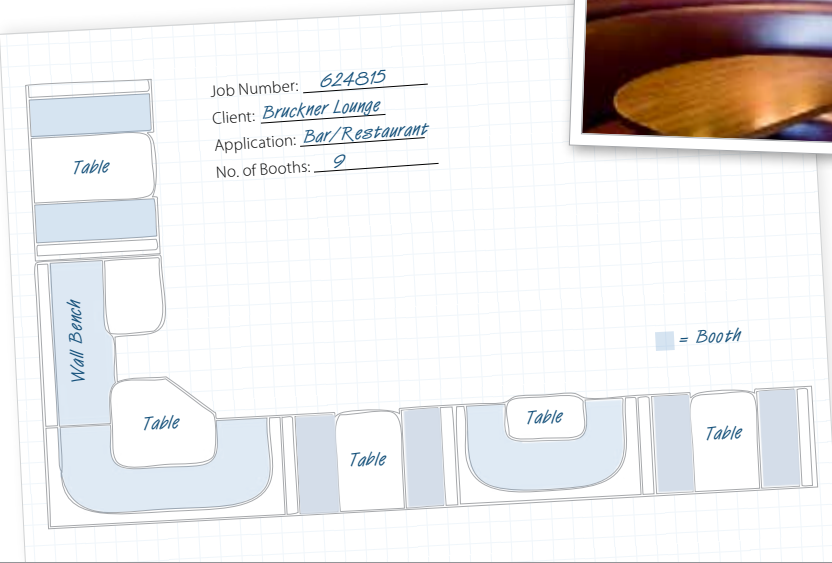

Booths can be designed and configured to fit each unique space.

2 DESIGN YOUR BOOTH

What dimensions suit your needs? Design your booth specifying back height, seat height, booth shapes and configurations.

TOP CAP & END PANELS
Depending on your design, end panels and top caps may be wood, laminate, or upholstery.

SEAT
Let us help you determine the right type of seat for your application. Optional wipeout channels available.



BASE VS LEGS
Whether traditional or contemporary, design your booth with a box base, wood or metal legs.



OUTSIDE BACK
Many options available; upholstery, laminate, veneer

INSIDE BACK
Design your inside back, options are limitless.



+ TECHNOLOGY
Power consoles and outlets can be added to many styles.

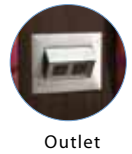

3 PLACE ORDER & CONFIRM THE DETAILS

- ✓ Provide your floor plan.
- ✓ Place your order.
- ✓ We can help with field dimensions.
- ✓ Approve our final shop drawings.

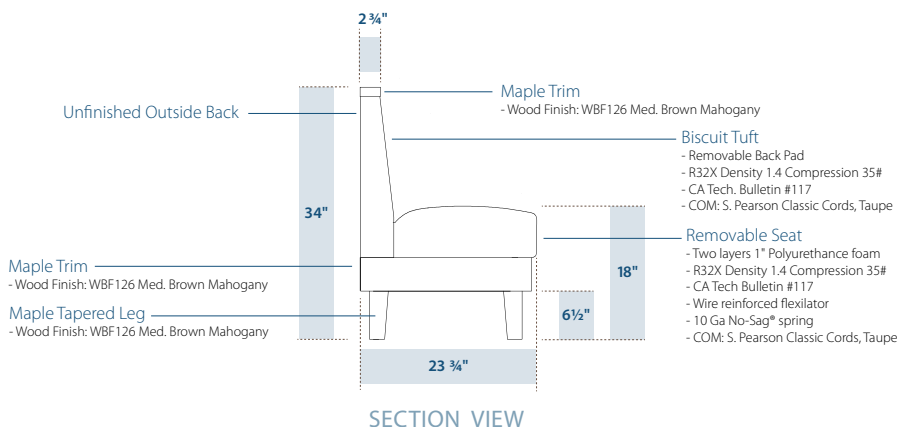
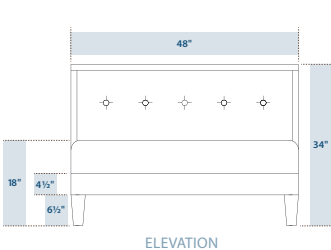

LET US HELP YOU!

Call today, tell us your challenge, let us work with you to develop a truly customized solution.

Visit shelbywilliams.com | 1-800-873-3252